

Stiftwechsel für größere Türstärken PIATTA S / Square pin change for larger door thickness PIATTA S

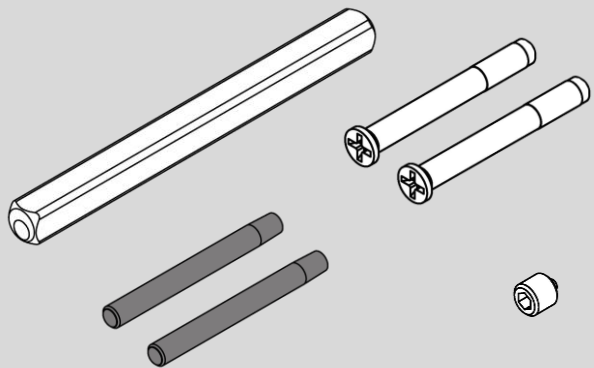

SICHERHEITSHINWEISE: Der Vierkantstift ist mit einer Feder gespannt. Beim Aushängen der Feder muss das Werkzeug und der Griff gut festgehalten werden um Verletzungen zu vermeiden / **SAFETY-RELATED INFORMATION:** The square pin is stretched with a spring. When unhooking the spring, the tool and handle must be held firmly to avoid injury
WARTUNG UND PFLEGE siehe Montageanleitung Drückergarnitur / **CARE INSTRUCTIONS, SERVICE AND MAINTENANCE** see mounting instructions handle set

Lieferumfang / scope of delivery



Arbeits-Ansicht / Work view

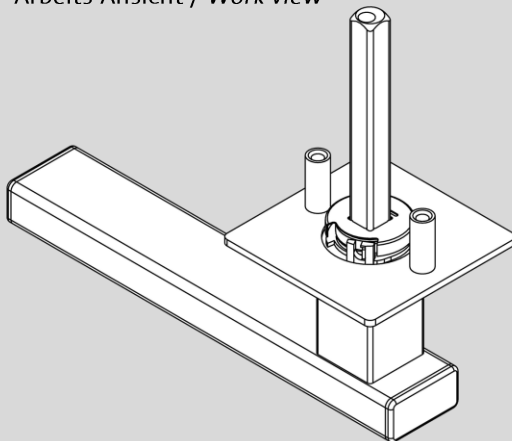

Montagewerkzeug / assembly tools

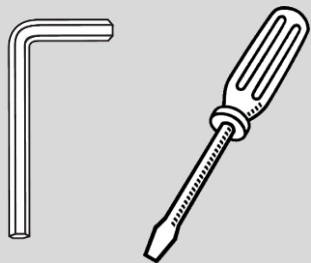

SW 3

0,5 x 3

Nur bei Schlüsselrosetten / only with key roses

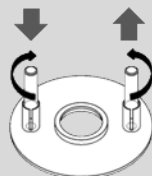

Pins korrekt einstellen
Set the pins correctly

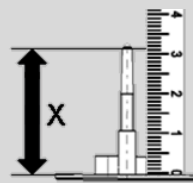

$$X = T - 6\text{mm}$$

T = Türdicke / door thickness

